



## AIR-ZENITH OB2 Owner's Manual

Congratulations! Thank you for purchasing the world's fastest DC 12-Volt air compressor by AIR-ZENITH. Air-Zenith quality products are manufactured by the people who know pneumatic air suspension systems inside and out. Our R&D people take pride in doing it right the first time, every time. This installation manual will help guide you through the proper and safe installation of your compressor to ensure years of reliable service. Thank you for your support! **PLEASE READ THIS MANUAL CAREFULLY BEFORE OPERATING THIS PRODUCT.**

### MODELS

- AZ-OB2

### PRODUCT SPECIFICATIONS

- Motor Voltage: DC 12-Volt
- Motor Class:  $\frac{3}{4}$  Horsepower
- Max. Amp Draw: 35A
- Max. Working Pressure: 200 PSI
- Duty Cycle: 100% (at 200PSI & 72 °F)
- Max. Ambient Air Temp.: 158 °F
- Min. Ambient Start Temp: -40 °F
- Thermal Protector: Yes

### STANDARD FEATURES

- Oil-free design, non-lube piston & cylinder.
- Patented Interchangeable Piston Technology.
- Long-life, PTFE compound piston ring.
- Balanced connecting rod, low vibration, low sound levels.
- Direct driven motor with automatic reset thermal overload protector.
- IP55 Certified Waterproof cooling fan.
- $\frac{1}{2}$ -inch PTFE-lined stainless steel braided air hose with  $\frac{1}{2}$ -inch NTP air tank fitting.
- Heavy duty anti-frozen check valve.
- Remote mountable weather proof air filter.
- 80A heavy duty relay with factory pre-wired relay socket.
- Integrated 3-position mounting brackets with NYLOCK self-locking mounting hardware.



- Image shown above is a side mounted Air-Zenith OB2 BLACK (P/N: AZOB2K).

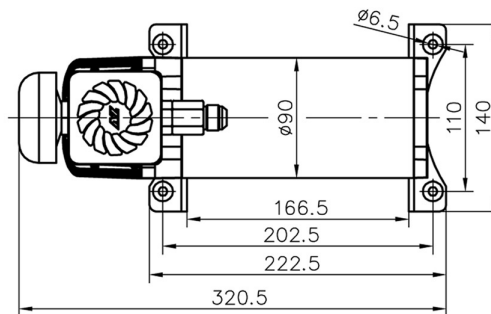
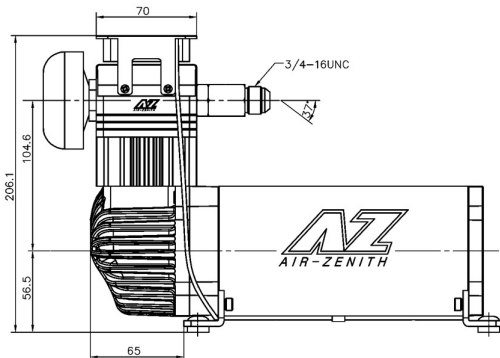

**[WWW.AIR-ZENITH.COM](http://WWW.AIR-ZENITH.COM)**

(Fig. 1 Standard Wiring Diagram)

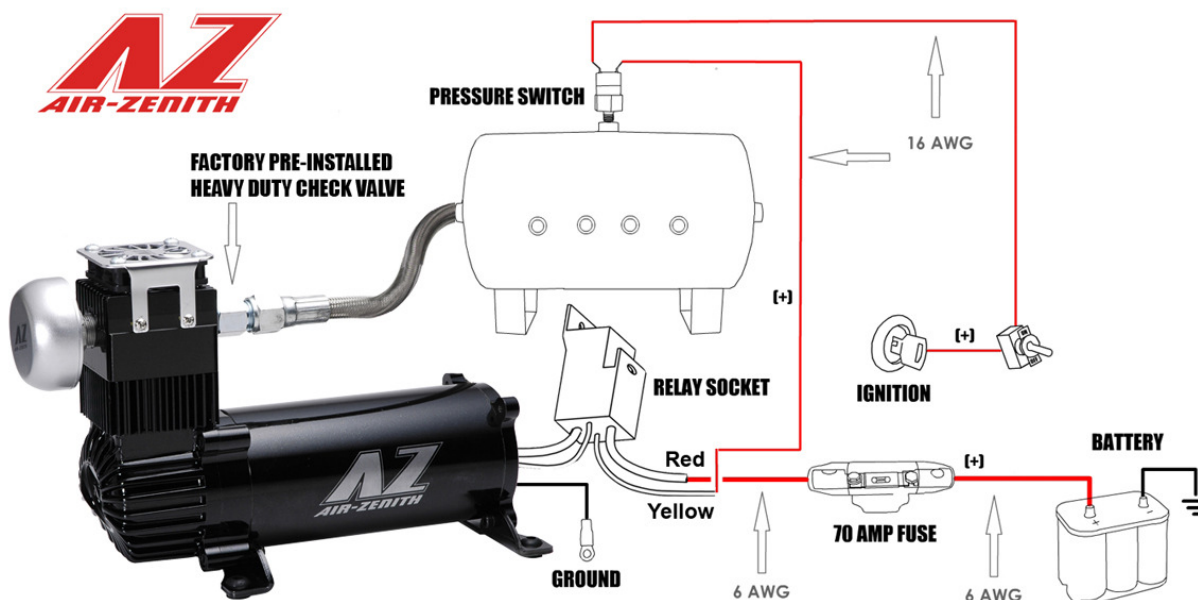

## 1. PRE-INSTALLATION NOTES

- Air-Zenith products must be installed by a qualified professional installer.
- Air-Zenith accepts no responsibility for products or components provided by other manufacturers for use with or around the Air-Zenith products.
- Disconnect your vehicle's battery before installation. Be sure to wear proper eye and hand protection during installation.
- **Do not attempt to remove or alter factory pre-installed 80A relay or relay socket. Any modification to factory pre-installed relay socket will void product warranty.**
- Make sure that your compressor setup is properly fused. Install a 70A or larger fuse as close to the battery positive post as possible. Note: Air-Zenith does not recommend circuit breakers, a high quality 70A or larger ANL-fuse and fuse holder is highly recommended.
- Choose mounting location that is as cool as possible and away from any heat source. The cooler the ambient temperature the less chance the compressor will overheat.

## 2. INSTALLATION GUIDELINES

- To maximize air compressor performance, mount the compressor as close to the battery as possible.
- This compressor is moisture & splash resistant, but not water proof! Do not mount compressor in locations where the unit is likely to come in contact with water.
- **This compressor comes with pre-installed 80A relay with pre-wired relay socket. Connect your battery positive power wire to the Red wire on the relay socket. (Run minimum 6AWG wire for wire length runs more than 10 feet, and 8AWG wire for length shorter than 10 feet).**
- **Install a 200 PSI (or under) pressure switch on the air tank. (Maximum 5-gallon air tank for one compressor). Connect one of the pressure switch wires to Key Ignition positive power wire. Connect the other pressure switch wire to the Yellow wire on the relay socket. (See Fig. 1 for standard wiring diagram).**

- This compressor has a pre-installed check valve located at the cylinder head. Do not remove that check valve; connect supplied braided air hose to the check valve, and then connect air hose to the air tank with supplied ½-inch NPT fitting.
- Connect compressor ground wire to vehicle chassis. You will want a place clear of paint and debris; you can lightly sand away body paint if needed. Drill a mounting hole for your fastener. Attach your compressor ground wire and apply a light coat of grease or paint to keep the connection clean. Note: If possible, route compressor ground wire to your battery negative post for maximum performance.

### 3. OPERATION GUIDELINES

- To prevent unwanted discharge of your vehicle's battery it is strongly recommended to keep your engine running while operating this compressor.
- This compressor is oil-free. Never try to lubricate piston and cylinder with motor oil or WD-40. Make sure cylinder and piston is clean and free of obstruction.
- Periodically check all electrical components. Inspect all connections for leaks with soap and water solution. If a leak is detected, tighten connections if needed.
- **This compressor will become very HOT during and immediately after use. Do not touch this compressor with bare hands during and immediately after usage.**
- **This product is equipped with Automatic Reset Thermal Protection. In the event this unit reaches an unsafe operating temperature, thermal protector will cut power to prevent damage to the motor, and can automatically restart when temperature returns to a safe operating level. When thermal protector is activated, stop operation for at least 30 minutes.**

**WORLD'S FASTEST AIR RIDE COMPRESSOR**

**AIR-ZENITH OB2**

**200 PSI | 100% DUTY | 35 AMP DRAW | 3.8 CFM**

OB2-CHROME    OB2-BLACK    OB2-WHITE    OB2-SILVER

Complete Air Suspension Kits Available, Shop Online at:  
**WWW.AIR-ZENITH.COM**

**SEMA** 2009 SEMA SHOW  
BOOTH #46072  
SOUTH HALL

**WWW.AIR-ZENITH.COM**

#### 4. TWO YEARS LIMITED WARRANTY

Air-Zenith warrants this product to be free from defects in material or workmanship under normal use and service; and limits the remedies to repair or replacement. This warranty shall extend for a period of two years from the original owner and original date of purchase, and is valid only within the continental limits of the United States and Canada.

Air-Zenith reserves the right to examine any warranty claim to determine the cause of failure. Air-Zenith's obligation under this warranty shall be limited to repairing, replacing, or crediting at its option any part proven defective. No labor, lift, service or storage charges will be reimbursed for any reason. Damages to Air-Zenith compressors resulting from misuse or abuse shall void this limited warranty. Any return freight charges must be prepaid by the customer. Air-Zenith shall not be liable for any damage or injury to persons or property resulting from improper installation or misuse of this product. If it is due to improper installation or misuse, a repair charge will be assessed and the customer will be contacted before work is performed or replacement parts are shipped.

**AIR-ZENITH (USA) | 3010 West Post Road | Las Vegas | NV | 89118 | USA**

**Tel: 702.270.7988 | Fax: 702.270.7966 | Email: sales@air-zenith.com**

**HI-PERFORMANCE AIR SUSPENSION KITS 100% BOLT-ON FOR:  
300C, MAGNUM, CHARGER, CHALLENGER (NEW LX CHASSIS)**

**AIR-ZENITH | 702-270-7988**

**AIR-ZENITH OB2 SPECIFICATION:**

AIR FLOW:	3.8 CFM
DUTY CYCLE :	100% DUTY
MOTOR CLASS:	3/4 HP MOTOR
0-200PSI 5GA TANK:	5 MINUTES
165-200PSI 5GA TANK:	1 MIN. 30 SEC.
AIR HOSE SIZE:	1/2" BRAIDED
CHECK VALVE :	HEAVY DUTY
POWER RELAY:	80A PRE-WIRED
COOLING FAN:	IP55 WATERPROOF
WARRANTY:	2 YEARS

**[WWW.AIR-ZENITH.COM](http://WWW.AIR-ZENITH.COM)**